

C&H SERVICES SBU



The image illustrates the Effimonitor system components. At the top center is a blue industrial boiler. Below it is a grey control cabinet with a touch screen HMI. To the right, a computer monitor displays a software interface with a graph and data points. Red arrows indicate the flow of information: from the boiler to the control cabinet, from the control cabinet to the computer monitor, and from the computer monitor back to the boiler. The background features a collage of Indian currency notes and a grid pattern.

Effimonitor™

The complete efficiency monitoring system for boilers

■ What is Effimonitor™?

It is a PLC based efficiency monitoring unit, which takes input from key field instruments and does performance analysis of the boiler. It displays important parameters locally on a touch screen HMI. System monitors 15+ parameters which are analysed for better load management and to undertake proactive actions leading to decrease in fuel bill. The system is suitable for oil fired (FO/HSD/LDO), Gas fired (NG/LPG) and Solid Fuel fired boiler & heaters.

Parameters for monitoring *	
Stack oxygen (%)	Totalised mass flow of steam (kg)
Stack temperature (°C)	CO ₂ %
Steam temperature (°C)	Excess air %
Steam flow (kg/hr)	Losses as per BS 845 (%)
Steam pressure (kg/cm ²)	Indirect efficiency (%)
Feed water temperature (°C)	Fuel consumption (kg/hr)
Ambient temperature (°C)	Steam to fuel ratio
Air / Fuel ratio control (Solid Fuel)	Draft Control (Solid Fuel)
Blow down control	Water flow

Efficiency monitoring system can be offered for either direct or indirect method

* Select desired parameters, before ordering

Effimonitor -

- Indicates boiler's health by displaying the operating efficiency as per BS 845, and helps take corrective action
- Remotely displays parameters at utility manager's desk
- Stores boiler performance data for long periods for review
- Provides user-friendly interface and error free electronic logbook
- Tailor-made reports / trends (as optional)

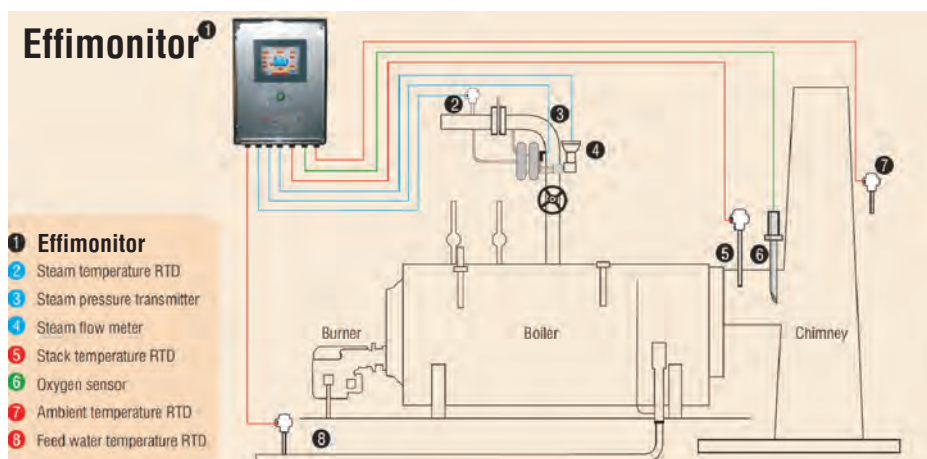

Benefits

- Continuous monitoring of performance parameters for prompt actions to improve boiler efficiency and for better utilisation of fuel
- Better load management
- Planning proactive preventive maintenance
- Simple error free data logging as if it's the electronic logbook of your boiler

Effimonitor components

- Programmable logic controller (PLC)
- Touch screen human machine interface (HMI)
- Field instruments
- SCADA

For more information, please get in touch with your nearest Thermax Representative. You can also mail us at info.c&hservices@thermaxindia.com visit us at: www.thermaxindia.com

In view of our constant endeavour to improve the quality of our products, we reserve the right to alter or change specifications without prior notice. All photographs shown in this publication are representative in purpose, and to be used for reference only. For actual details and specifications, please refer to Thermax offer document.



THERMAX

Sustainable Solutions in
Energy & Environment

COOLING & HEATING DIVISION Services SBU

D - 13, MIDC Industrial Area, R. D. Aga Road,
Chinchwad, Pune 411 019. INDIA
Tel. : +91-20-2747 5941
Fax : +91-20-2747 7080
E-mail : info.c&hservices@thermaxindia.com

AHMEDABAD 380 006

Tel. : (079) 2657 5408 / 5341 / 7073
Fax : (079) 2657 7270
E-mail : aadmin@thermaxindia.com

BANGALORE 560 020

Tel. : (080) 2346 7761 - 84
Fax : (080) 2346 7760
E-mail : adminblr@thermaxindia.com

CHENNAI 600 018

Tel. : (044) 2435 3831 - 34
Fax : (044) 2435 3841
E-mail : chennaidivsupp@thermaxindia.com

HYDERABAD 500 482

Tel. : (040) 2339 6820, 2331 0254
Fax : (040) 2331 2335
E-mail : hyd_sec@thermaxindia.com

MUMBAI 400 016

Tel. : (022) 2204 5391, 2204 5324
Fax : (022) 2204 0859
E-mail : psecret@thermaxindia.com

NEW DELHI 110 057

Tel. : (011) 2614 5319, 2614 5701
Fax : (011) 2614 5311, 2614 8679
E-mail : psupport@thermaxindia.com

KOLKATA 700 017

Tel. : (033) 2282 6711 - 13
Fax : (033) 2282 6796
E-mail : mbiswas@thermaxindia.com

International Offices:

MIDDLE EAST (DUBAI)

Tel: +9714-8861424; E-mail:
info@thermaxdubai.ae

SOUTH EAST ASIA (MALAYSIA)

Tel: +60127798493
Email: thermax@tm.net.my

HO, AFRICA, SAARC & OTHER COUNTRIES

Tel: +91-20-66128802/8818/8845
Email: info.c&hservices@thermaxindia.com

International offices:

Indonesia, Russia, Kazakstan, Saudi Arabia,
Bangladesh, Sri Lanka, Hong Kong, China,
Thailand, Malaysia, Philippines, UAE, Kenya,
Nigeria, Brazil, UK, USA

Thermax Business Portfolio

Boilers & Heaters

Absorption Cooling

Air Pollution Control

Captive Power

Chemicals

Water & Waste Solutions